



Chrysler Pacifica



With four best-in-class options to choose from, you can pick the BraunAbility® Pacifica that's the perfect fit for your family. Discover the vehicle you deserve from the most trusted name in mobility.*

*Based on 2016 Dealer Service Technician Study

FIND YOUR *go*



BRAUNABILITY® SIDE-ENTRY POWER INFLOOR BUILT ON THE CHRYSLER PACIFICA

The BraunAbility Pacifica Infloor features patent-pending engineering technology that creates the widest doorway space and ramp of any side-entry vehicle on the market. Pair that with best-in-class interior cabin space, and you have the ultimate in mobility maneuverability.

- Best-in-class interior maneuverability
- Extra-wide ramp and doorway
- 55-inch doorway height
- Full-length, foldaway 3rd row footrest
- Soft glow cabin lighting
- Fully automatic door and ramp



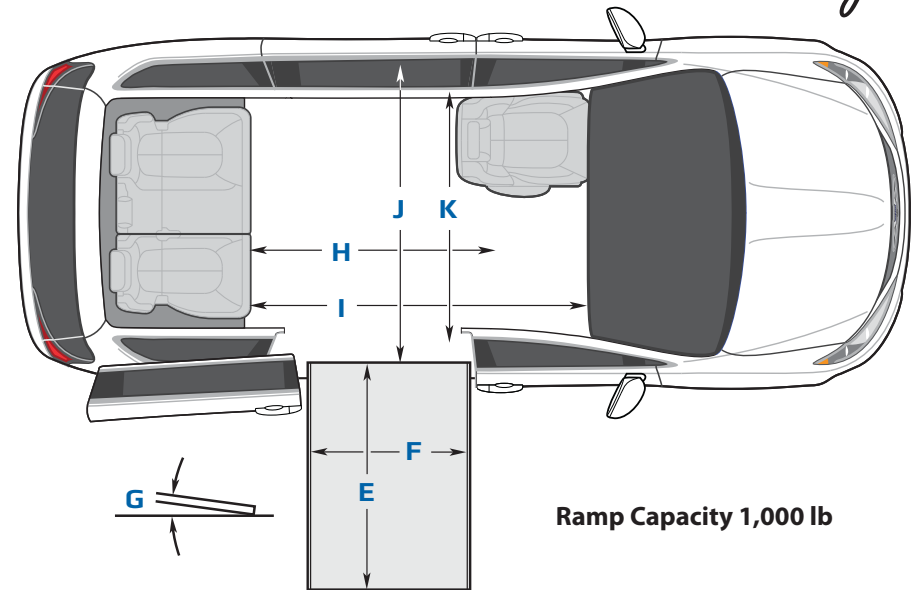
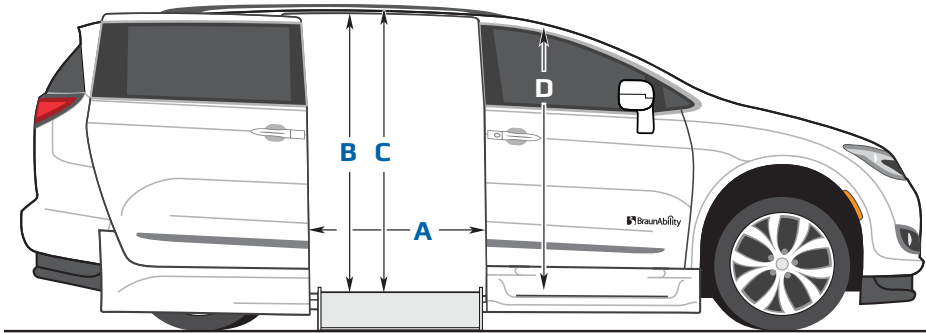

Ramp Capacity 1,000 lb

BRAUNABILITY® SIDE-ENTRY POWER INFLOOR BUILT ON THE CHRYSLER PACIFICA

DIMENSIONS

Door Opening Usable Width	A	33.5"
Door Opening Usable Height (at Middle of Door)	B	55"
Interior Height at Center of Van	C	58"
Interior Height at Driver/Passenger Position*	D	58"
Ramp Length	E	51.25"
Ramp Width (Usable Clear Opening)	F	32.25"
Ramp Angle** (with Vehicle Kneeled)	G	9.9°
Interior Floor Length (Behind Front Seat Strikers)	H	71"
Overall Interior Floor Length (Flat Area)	I	98.5"
Interior Width at Slide Doors (Door Closed)	J	68"
Interior Width at B Pillars	K	59.75"

All dimensions are for reference only.



Infloor Ramp

With a ramp angle of 9.9° and a smooth transition plate, the BraunAbility infloor ramp makes entering and exiting effortless.

Due to manufacturing tolerances both with the OEM vehicle and the conversion components, all dimensions may vary slightly from those shown.

* Deduct 1" off of Interior Height for Applications with Moon Roof

** Ramp angle subject to 1.5 degree variance based on chassis trim level and other environmental factors - measured with a 250 lb approximated wheelchair passenger load at the center of the ramp



FOLDOUT



FOLDOUT XT

BRAUNABILITY® SIDE-ENTRY POWER FOLDOUT & XT BUILT ON THE CHRYSLER PACIFICA

The BraunAbility Pacifica Foldout and Foldout XT both offer industry-leading interior space but with different doorway and interior heights to accommodate shorter and taller wheelchair users.

- Best-in-class interior maneuverability
- 53" and 57" doorway height options
- Full-length, foldaway 3rd row footrest
- Soft glow cabin lighting
- Fully automatic door and ramp



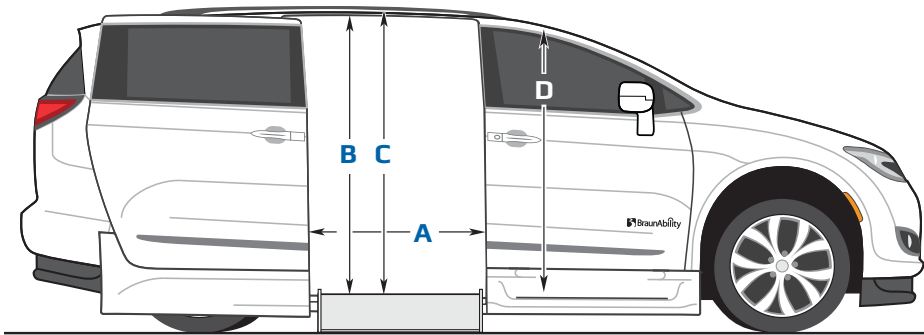

Find Your Foldout Fit

The Pacifica Foldout XT gives extra doorway height for wheelchair users who sit taller in their chairs, while the Pacifica Foldout is ideal for those who sit lower in their chairs.

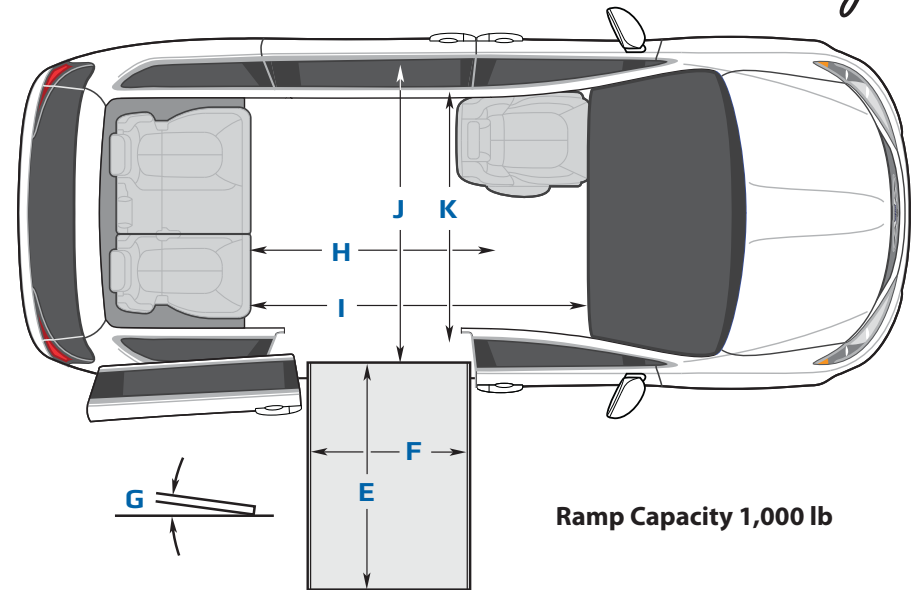

Ramp Capacity 1,000 lb

**BRAUNABILITY® SIDE-ENTRY
POWER FOLDOUT & FOLDOUT XT
BUILT ON THE CHRYSLER PACIFICA**

DIMENSIONS

Door Opening Usable Width	A	32.375"
Door Opening Usable Height (at Middle of Door)	B	53" (57" XT)
Interior Height at Center of Van	C	56" (60" XT)
Interior Height at Driver/Passenger Position*	D	56" (60" XT)
Ramp Length	E	52"
Ramp Width (Usable Clear Opening)	F	30.125"
Ramp Angle** (with Vehicle Kneeled)	G	9.1° (8.6° XT)
Interior Floor Length (Behind Front Seat Strikers)	H	71"
Overall Interior Floor Length (Flat Area)	I	98.5"
Interior Width at Slide Doors (Door Closed)	J	64"
Interior Width at B Pillars	K	62.25"

All dimensions are for reference only.



Heavy-Duty Foldout Ramp

With a 1000 lb. ramp capacity, this ultra-strong foldout ramp can also deploy onto curbs for added parking convenience.

Due to manufacturing tolerances both with the OEM vehicle and the conversion components, all dimensions may vary slightly from those shown.

* Deduct 1" off of Interior Height for Applications with Moon Roof

** Ramp angle subject to 1.5 degree variance based on chassis trim level and other environmental factors - measured with a 250 lb approximated wheelchair passenger load at the center of the ramp



BRAUNABILITY® REAR-ENTRY MANUAL BUILT ON THE CHRYSLER PACIFICA

The BraunAbility Pacifica Rear-Entry offers premium quality and value, all with the reliability you expect from BraunAbility. It also has the widest ramp and tallest entrance, allowing plenty of room for even the largest wheelchairs or scooters.

- 56" entrance height
- 34" ramp width - industry-leading!
- Flexible seating positions for wheelchair passenger
- Two-lock securement system prevents ramp rattle
- Lightweight, easy-to-operate manual ramp



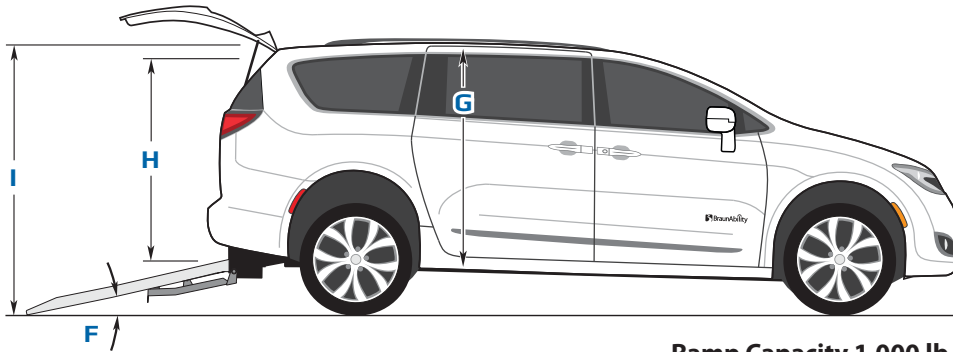

Ramp Capacity 1,000 lb

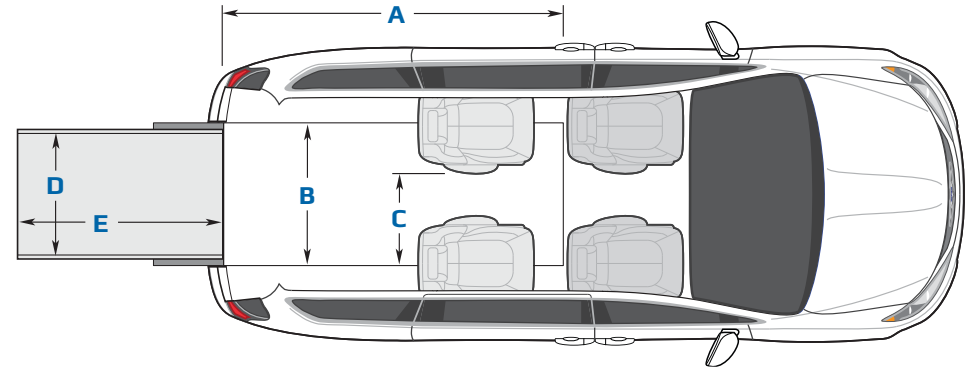

BRAUNABILITY®
REAR-ENTRY MANUAL
BUILT ON THE CHRYSLER PACIFICA

DIMENSIONS

All dimensions are for reference only.

Lowered Floor Length	A	98"
Lowered Floor Width	B	34.5"
Distance Between Seats (1 Folded Up)	C	25.5"
Ramp Width (Usable Clear Opening)	D	34"
Ramp Length (Manual Foldout)	E	60"
Ramp Angle*	F	10°
2nd Row Wheelchair Location Interior Height	G	56"
Entrance Height	H	56"
Overall Height (Hatch Closed)	I	75"

Due to manufacturing tolerances both with the OEM vehicle and the conversion components, all dimensions may vary slightly from those shown.

* Ramp angle subject to 1.5 degree variance based on chassis trim level and other environmental factors - measured with a 250 lb approximated wheelchair passenger load at the center of the ramp



Room to Move

Our most spacious rear-entry wheelchair van, the BraunAbility Pacifica offers 56" of door height and 34.5" interior width, so you have plenty of room to enter and exit.



THE MOST TRUSTED BRAND IN MOBILITY*

BraunAbility quality and reliability are recognized as the standards in automotive mobility. That's why the professionals at the forefront of helping our customers recommend our products.

- **Dealer Service Technicians** – choose BraunAbility 8:1 over the next closest competitor as the brand they would buy for a family member*
- **Permobil**® – makers of the best fitting, best performing, most technically advanced wheelchairs in the world
- **B&D Independence**® – the award-winning provider of innovative, quality seating solutions for wheelchair users

*Based on 2016 Dealer Service Technician Study

permobil

B&D
INDEPENDENCE

800.488.0359 | braunability.com

